



STIMPOD™

NMS 410/450X

Quantitative NMT Monitor
Precision Nerve Locator

AVANT
TECHNOLOGY

Product Code: XT-45006-EN

CE 1639 XM400-21A04 v12

Manufacturer

Xavant Technology PTY (LTD)

Unit 102, The Tannery Industrial Park, 309 Derdepoort Rd

Silverton, Pretoria, South Africa, 0184

Tel: +27 (0) 12 743 5959

Fax: +27 (0) 86 547 0026

E-mail: support@xavant.com

Web: www.xavant.com

Legal Representative in the EU

Emergo Europe

Prinsessegracht 20, 2514 AP The Hague

The Netherlands

EU Importer

MedEnvoy

Prinses Magrietplantsoen 33 – Suite 123

2595 The Hague, The Netherlands

Caution

Federal (US) law restricts this device to sale by or on the order of a physician.

Indications for use:

This product is a nerve stimulation device designed to be used by an anaesthetist during

- General Anaesthesia, for the purpose of establishing the efficacy of a Neuromuscular Blocking Agent using non-invasive surface electrodes (NMS450X).
- Regional Anaesthesia for the purpose of
 - Nerve mapping using the non-invasive Nerve Mapping Probe (supplied).
 - Nerve locating using invasive electrodes/needles (not supplied).

Contraindications:

- Infection of the puncture site.
- Known neurological disorders.
- Severe coagulation disorders.

Warnings:

- Read the entire User Manual before attempting to use the device.
- Use of cables or accessories other than those supplied with the STIMPOD may result in serious injury.
- Maintenance on this device may only be performed by the manufacturer or persons explicitly authorized by the manufacturer.
- Do not use the STIMPOD in close proximity to equipment that produces strong electromagnetic fields, such as high frequency surgical equipment. The cable leads could act as antennae and dangerous currents could be induced as a result.
- Do not apply the STIMPOD to patients with implanted electrical devices, such as cardiac pacemakers, without first consulting with an appropriate medical specialist.
- The device should not be used adjacent to or stacked with other equipment and that if adjacent or stacked use is necessary, the device should be observed to verify normal operation in the configuration in which it will be used.
- The patient should avoid contact with metallic objects that are grounded, produce an electrical conductive connection with other equipment and/or enable capacitive coupling.
- The cables should be positioned in such a way that they do not contact either the patient or other cables.
- Simultaneous connection of a patient to high frequency surgical ME equipment and the STIMPOD may result in burns and possible damage to the stimulator.
- Operation in close proximity (e.g. 1m) to a shortwave or microwave therapy ME equipment may produce instability in the stimulator output.
- Application of electrodes near the thorax may increase the risk of cardiac fibrillation.
- No modification of this equipment is allowed.
- Do not modify this equipment without authorization of the manufacturer.
- If this equipment is modified, appropriate inspection and testing must be conducted to ensure continued safe use of the equipment.

Cautions:

- Prior to changing the batteries be sure to switch off the device and remove all the cables.
- Remove elements which may adversely affect the connection between the electrodes and the skin, e.g., dirt, hair, oil.
- Prior to placing any applied part (such as Accelerometer, ECG and EMG Electrodes), inspect the skin area for any pre-existing conditions and avoid if possible.
- Ensure that electrodes are not damaged or dried out.
- Large current densities associated with failing electrodes may cause superficial burns.
- For acceleromyography, the Stimpod is designed to be compatible with standard ECG electrodes, however, for high currents the use of a dedicated NMT electrode such as the Xavant XT45008 is recommended.
- Electrodes that have current densities exceeding 2mA/cm² may require special attention of the operator.
- This product must be stored at 0 – 50°C.
- This product must be transported in the carry case provided.
- This product and all the accessories have been certified latex free.
- Inspect all parts for any damage or manipulation. Never use any damaged or manipulated part!
- If an electrically conductive surface of the Stimpod device or its cables are exposed, such electrically conductive surface may shock a person handling it. Do not use such a device or accessory, please contact the manufacturer for repair.
- The refractory period delay is set at a default value to prevent the user from repeating stimulation while the nerve synapse is recovering from effects of the previous stimulation. A refractory period of less than 12 seconds in TOF mode is not advisable as measurements might not represent the effect of blocking agents on the neuromuscular junction.
- Do not place the STIMPOD stimulation electrodes in close proximity to other sensing electrodes i.e. EEG or ECG electrodes.

Application Specification:

- The patient population includes patients of all ages, weight and nationality. Patient health and state is described in contraindications, warnings and cautions.
- The user must be a medical professional with knowledge of anatomy.
- The use environment requirements of the device such as the medical practice and

operating room is described in the guidance and manufacturers declaration.

- The device can be used on any part of the body except for limitation described in warnings and cautions or identified in section 3 for the NMT mode.

Warranty:

- The Stimpod (device only) carries a 24 month warranty against manufacturing defects, provided that the device was used in accordance with the operating instructions.
- The cables included in the Stimpod kit carry a 6 month warranty against manufacturing defects, provided that the cables were used in accordance with the operating instructions.
- The Stimpod enclosure should not be opened under any circumstances. Opening the unit will void the warranty.

STIMPOD (NMS 410/450X) conforms to the following standards:

- IEC 60601-1, IEC 60601-2-10, IEC 60601-2-40
- IEC 60601-1-2: CISPR 11 Group1 class A; IEC 61000-4-2; IEC 61000-4-3
- ISO 13485, Directive 93-42-EEC

Contents

1. Getting to know the STIMPOD (NMS 410/450X)	5		
1.1) Device Description	5	3.6) Adjusting the Current	22
1.2) Device Layout	6	3.7) Adjusting Stimulation Mode	22
1.3) Screen Layout	7	3.8) Adjusting the Twitch/ Tetanus Frequency	22
1.4) Accessories	8	3.9) Train of Four Mode (TOF)	23
1.5) Warning Screens	10	3.10) Double Burst Mode (DB)	23
1.6) Open Circuit Detection	12	3.11) Post Tetanic Count Mode (PTC)	24
1.7) Auto Shutdown	12	3.12) Supra Maximal Current Mode (SMC)	24
1.8) Symbols	12	3.13) Auto Mode	25
		3.14) Twitch Mode	26
		3.15) Tetanus Mode	26
2. Nerve Locating/Mapping Mode (NMS 410/450X)	13	4. Setting up Device Defaults	27
2.1a) Adjusting the Current in LOC mode	14	4.1) Setup Menu	28
2.1b) Adjusting the Current in MAP mode	15	4.2) User Settings	28
2.2) Adjusting the Pulse Width	16	4.3) NMT Settings	29
2.3) Proximity Indicator	16	4.4) Locate Settings	30
2.4) Adjusting the Twitch Frequency	16		
3. Neuromuscular Transmission (NMT) Monitoring Mode (NMS 450X)	17	5. Technical Notes	32
3.1) Introduction to NMT Monitoring	17	5.1) Performance Testing	32
3.2) Cables and Sensors for NMT Monitoring	17	5.2) Specifications	36
3.3) Stimulation Sites for NMT Monitoring	18	5.3) Cleaning and Disinfecting STIMPOD	36
3.4) AMG Patient Setup	19	5.4) Guidance and Manufacturers Declaration	37
3.5) EMG Patient Setup	20		
		Products & Accessories	40

Getting to Know the STIMPOD (NMS410/450X)

1

1.1) Device Description

The STIMPOD NMS450X is a quantitative Neuromuscular Transmission (NMT) monitor utilizing either tri-axial accelerometry or electromyography to provide real-time quantitative feedback.

The Stimpod NMS 410 as well as Stimpod NMS 450X is also a precision nerve locating tool used for localizing specific neural pathways. Localization of nerves by electrical stimulation involves connecting the nerve stimulator to a conducting needle through which local anaesthetics can be injected. The distance of the needle (cathode) from the nerve can be estimated by establishing the minimum threshold current required, to facilitate a neuromuscular response.

CAUTION: This device should only be used by a qualified physician with appropriate knowledge in anaesthesia.
The sale or purchase of the device is restricted to licensed medical practitioners, as governed by the law of the country/state in which he/she practices, or where the device is to be used.

1.2) Device Layout

1 Cable Connector

Insert the combined Nerve Mapping / Locating Cable or the NMT cable to activate the relevant mode.

2 Enter / Frequency Button

Press to toggle between Frequencies.
Press to Enter in setup menu.

3 Menu / Pulse Width Button

NMS 410/450X (LOC/MAP Mode)

Press to toggle between Pulse Widths.
Press and hold to access Setup Menu.

NMS 450X (NMT Mode)

Press to toggle between Stimulation Modes.

4 Stimulating LED indicator

Flashing Green: Stimulus delivered.
Flashing Red: Open Circuit.

5 Pause Button

NMS 410/450X (LOC/MAP Mode)

Press to Stop / Start Stimulation.

NMS 450X (NMT Mode)

Press and release to elicit a single stimulation.

Press and hold to activate a repeated stimulation.

6 The Wheel

Adjust current in the main operating mode.
Navigate the Setup Menus.

7 On / Off Button

Press to switch unit on / off.

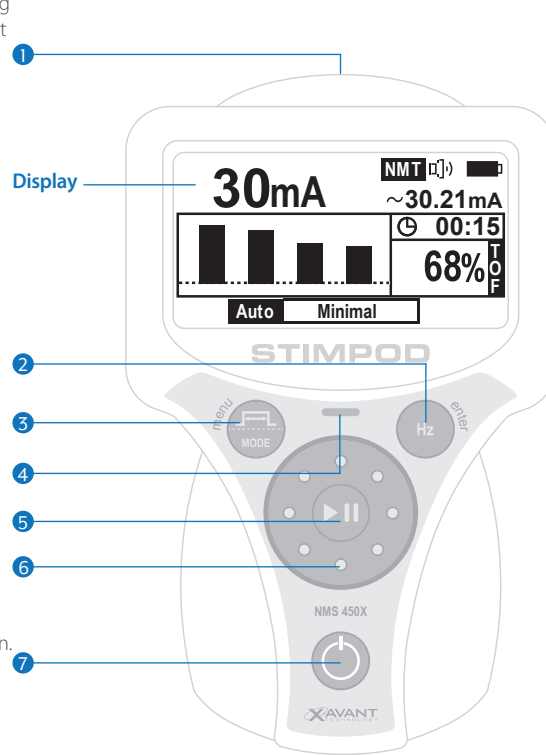

Multi Functional Clip

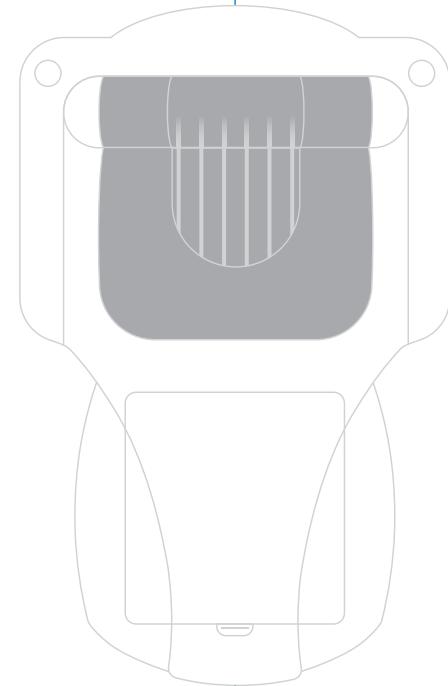

Battery Compartment Cover

1.3) Screen Layout

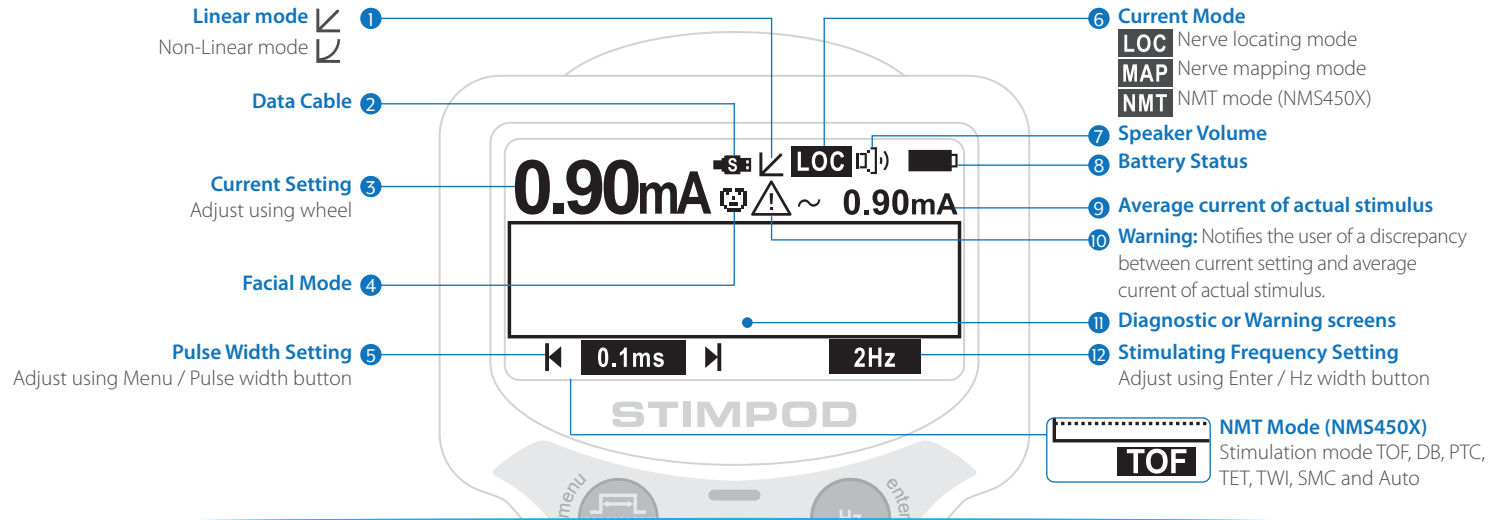

Diagnostic Screen NMS 410/450X (LOC / MAP Mode)

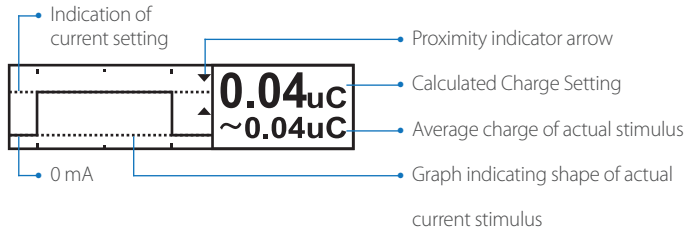

Diagnostic Screen NMS 450X (NMT Mode)

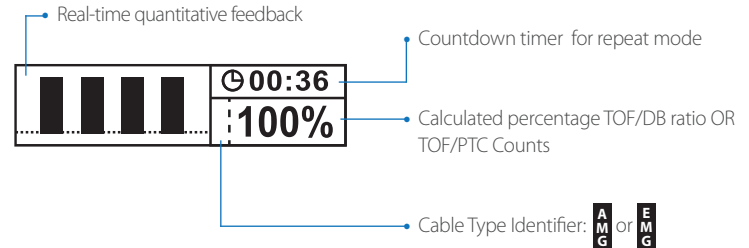

1.4) Accessories

WARNING: Use of cables or other accessories other than those supplied with the STIMPOD may result in serious injury.

NOTE: ECG Electrodes and Nerve Locating needles are not included in this package.

CAUTION: A sterile wipe should be applied to the Nerve Mapping Probe prior to use.

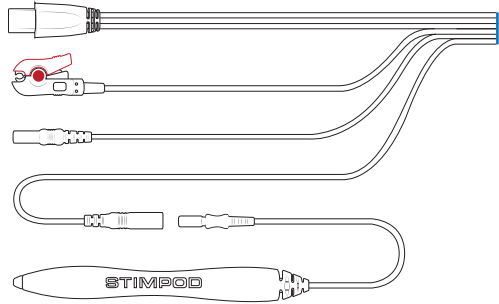

• **Nerve Mapping/ Nerve Locating Cable (XT-41014):**

- This cable is used to activate the Nerve Mapping/Locating mode on the STIMPOD.
- The red (anode) connector is designed to clip on to a standard ECG electrode.
- The ergonomically designed cutaneous Nerve Mapping Probe presents the user with a simple and reliable Nerve Mapping solution.
- The 2mm needle connector will accommodate various makes of needles.

AMG Accessories (STIMPOD NMS450X)

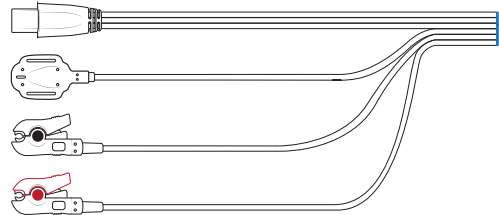

• **NMT Monitoring Cable AMG (XT-45025) and 3.5m (XT-45025A):**

- This cable is used to activate the NMT mode on the STIMPOD.
- The red (anode) and black (cathode) connectors are designed to clip onto the Xavant NMT electrode (XT-45008) or onto a standard ECG electrode.
- The accelerometer is designed to attach to the contracted appendage (in the case of the ulnar nerve, this will be the thumb).

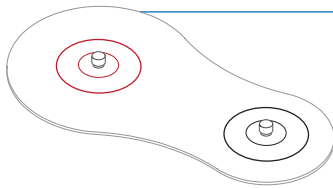

• **NMT Electrode (XT-45008):**

- The colour coded connections indicate the polarity for the NMT cable connections
- The larger surface area of the red (anode) electrode reduces the current density of the anode and prevents hyperpolarization
- The proprietary gel and gel interface was specifically designed for transmission of large currents.



EMG Accessories (STIMPOD NMS450X)



- **NMT Monitoring Cable EMG 1.8m (XT-45003) and 3.5m (XT-45003A):**
 - The EMG cable is used to enable EMG based NMT Monitoring on the Stimpod.
 - The EMG cable connects directly to the EMG Electrode.



- **EMG Electrode Large (XT-45009L) and Small (XT-45009S):**
 - The disposable EMG Electrode is applied directly to the patient for EMG based NMT Monitoring using the EMG cable.

Smart Data Cables (STIMPOD NMS450X)



- **Smart Data Cable Philips RS232 (XT-45100C-PHI):**
 - Interface AMG/EMG data directly to a compatible Philips monitor.



- **Smart Data Cable NMSHOW (XT-45100A-NMS):**
 - Interface AMG/EMG data directly to a PC using the NMSHOW software.



1.5) Warning Screens



Insert Cable:

This is the first prompt which the user will encounter as the unit is switched on, and signals that the unit is waiting for the cable to be inserted.



Pause:

This warning informs the user that the PAUSE button was pressed. The STIMPOD will pause all its activities and wait for the PAUSE button to be pressed again.

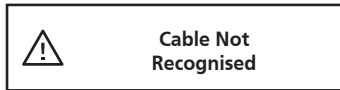

Cable not recognised:

This warning informs the user that the inserted cable is not compatible with the NMS 410/450X.



Replace Batteries:

This warning informs the user that the batteries are depleted beyond an acceptable level. Continuing to operate the device thus will make it unreliable. To prevent this the STIMPOD flashes this warning for 4 seconds before switching off.

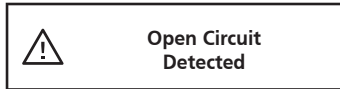

Open Circuit Detected:

This warning informs the user that the contact points of the connected accessory are not forming a closed circuit. This warning will be accompanied by a red flashing LED, every time the unit attempts to stimulate.



Current Adjustment in NMT Mode:

When attempting to adjust the current while in NMT mode the device will show this message, requesting the user to confirm the adjustment of the current.

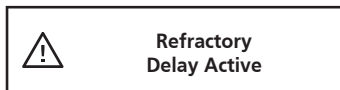

Refractory Delay Active:

Once a TOF, DB, or PTC stimulation is performed, the refractory period timer is initiated. During the countdown time it will not be possible to perform another stimulation. If another stimulation is attempted, this warning screen will appear.

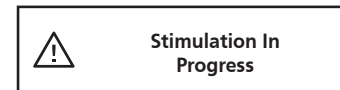

Stimulation in Progress:

Warning shown when the play button is pressed during stimulation.



EMI Warning:

Warning shown when a high level of electromagnetic interference is detected.



Component Error:

The STIMPOD has detected a component failure. Please send the device back to the manufacturer for repair!

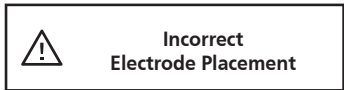

Incorrect/Check electrode placement:

Warning shown when SMC is unable to find a supramaximal current value.

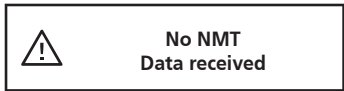

No NMT Data received:

Warning shown when either the AMG or EMG sensor did not respond.

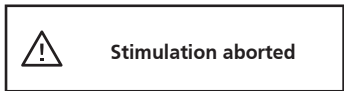

Stimulation aborted:

This warning is shown when:

- **SMC:** Measured current is more than 10% less or more than the set current.
- **NMT:** The stimulation was interrupted.

1.6) Open Circuit Detection

The Stimpod performs impedance measurements at regular intervals to detect whether the connection between the STIMPOD and the patient comprises a closed circuit.

Closed Circuit Detected:

- Stimulation will take place.
- Stimulating sound will be heard (Single or multiple beeps depending on proximity indicator setting. Sound pitch will follow the current intensity).
- The LED stimulus indicator will pulse green with every successful stimulus attempt.
- The diagnostic screen will provide active feedback on every pulse delivered.

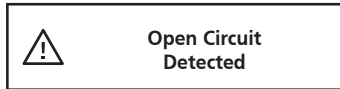

Open Circuit Detected:

- No stimulation will take place.
- No stimulating sound will be heard.
- The LED stimulus indicator will pulse red with every unsuccessful stimulus attempt.
- A warning screen will appear in the diagnostics screen indicating that an open circuit was detected.

1.7) Auto Shutdown

STIMPOD will shut down after 10 minutes of no user or patient interaction.

1.8) Symbols



Manufacturer



Manufacturing Date
(Year)



Caution



Separate collection
for electrical
and electronic
equipment
(Applicable to EU
community only)



Serial Number



Representative
in the EU



Catalogue Number



Prescription
use only



Type BF
Applied Part



Non-sterile



Humidity limitation

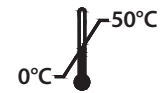

Temperature limit



Consult instructions
for use



Medical Device



EU Importer

2

Nerve Locating/Mapping Mode (NMS 410/450X)

Locating mode (LOC)

Localisation of nerves by electrical stimulation involves connecting the nerve stimulator to a conducting, locating needle (not supplied) through which local anaesthetics can be administered. This procedure involves subcutaneous stimulation of the motor component of the relevant peripheral nerve, to 'locate' the nerve.

- Select this mode by inserting the Nerve Locating / Mapping cable.
- The STIMPOD will automatically default to the Nerve Locating current range (0.00 - 5.00 mA) and display the 'LOC' indicator.

Mapping Mode (MAP)

Percutaneous nerve mapping enables the anaesthesiologist to map out a particular superficial nerve prior to nerve location with the needle. This is accomplished by stimulating the motor component of the relevant peripheral nerve percutaneously with the nerve mapping probe. This technique ensures a higher success rate for directing the needle to the correct nerve.

This mode offers the user the means to do nerve mapping and locating without having to switch or unplug cables.

When inserting the Nerve Mapping / Locating Cable, the STIMPOD will default to the Nerve Mapping current range (0-5mA). Current will be directed to the Nerve Mapping probe and the STIMPOD will attempt to stimulate. The moment that the needle penetrates the skin the cable will sense it and inform the STIMPOD. The stimpod will switch to Nerve locating mode. If contact between the needle and patient is broken, and the nerve mapping probe touches the patient, STIMPOD will switch back to the nerve mapping mode and start monitoring the needle - patient connection again. Whenever the nerve mapping probe and the nerve locating needle simultaneously make contact with the patient the needle will have first priority.

- This mode is selected when the Nerve Mapping / Locating cable is inserted.

When using the Nerve Locating / Mapping Cable

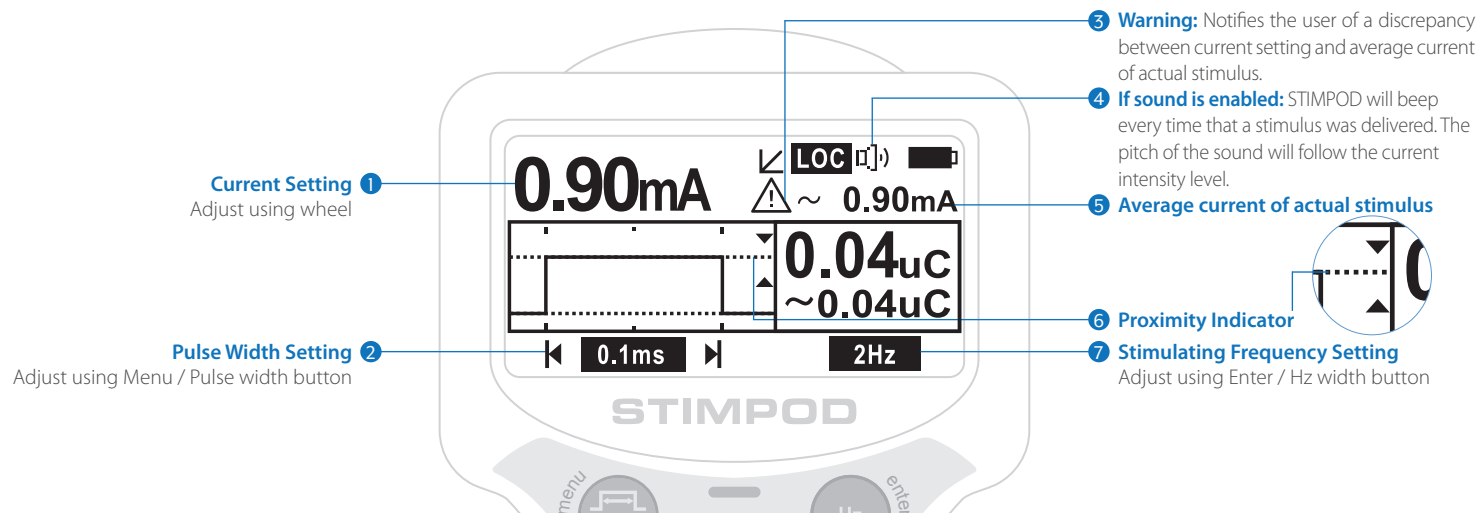

2.1a) Adjusting the Current in LOC mode 1

Current Mode Options: Linear Mode, Non-Linear Mode
Default: Linear

Linear Mode: ↙

The Linear Mode is called linear because one 'click' on the Wheel will correspond with one increment as set in the specific current range. The Linear Mode allows the user to select individual incrementing options for the three different current ranges.

Default Current range:

0.00 - 5.00mA adjustable in the following default increments:
0.0 - 0.6mA Default 0.1mA

0.6 - 2.0mA Default 0.2mA
2.0 - 5.0mA Default 0.5mA

Increments can be adjusted in the Setup Menus

Circle the Wheel to adjust current.

Non-Linear Mode: ↘

The Non-Linear Mode facilitates the non-linear nature of the current intensity versus the distance from the nerve. This mode allows the user to define 20 adjustment positions in terms of Current (mA) and Pulse Width (ms). If correctly implemented each adjustment position should afford the user with a relatively linear progression in terms of the distance from needle tip to the nerve.

Default Current and Pulse Width Range:

As shown in table 1 in section 4.4 circle the Wheel to select the predetermined current and pulse width positions sequentially.

NOTE: Because the 20 definable positions include both current and pulse width settings, pulse width cannot be adjusted independently in this mode. This is indicated on the screen by the fact that pulse width is not highlighted.

When using the Nerve Mapping Probe (NMS 410/450X):

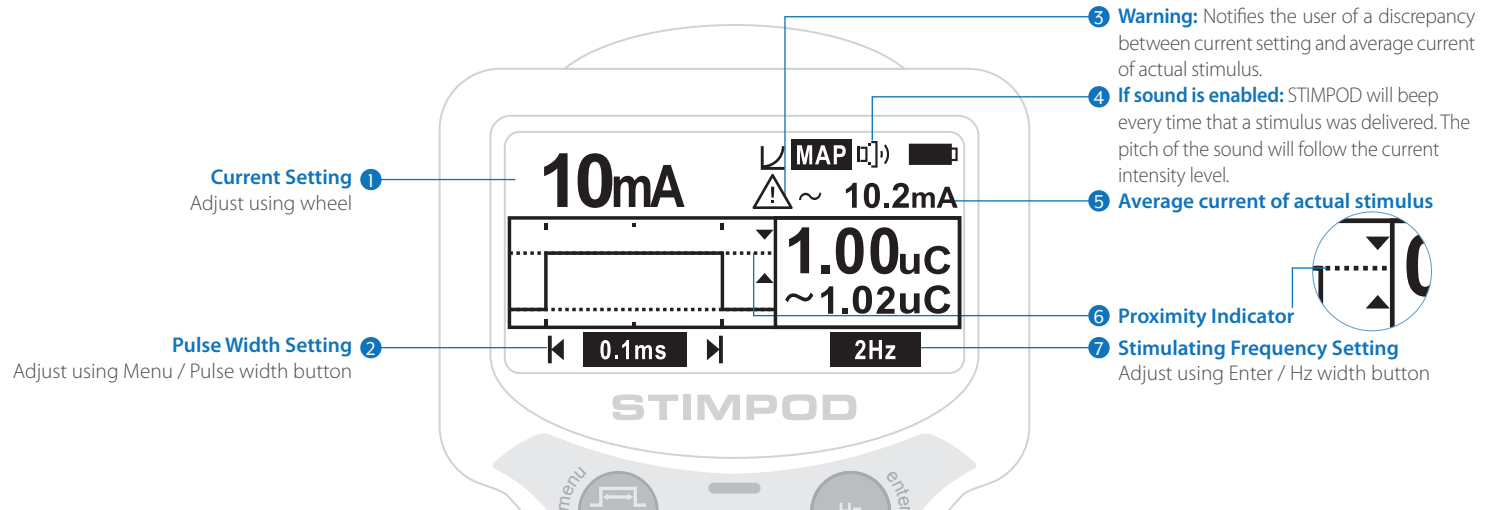

2.1b) Adjusting the Current in MAP mode 1

Current Range: 0 - 20mA adjustable in 1mA increments.
Circle the Wheel to adjust current.

NOTE: The STIMPOD will automatically default to the Nerve Mapping current range (0-20mA) and display the 'MAP' indicator.

2.2) Adjusting the Pulse Width 2

Options: 0.05ms, 0.1ms, 0.3ms, 0.5ms, 1ms

Default: 0.05ms

Press Menu/Pulse Width button to toggle between different Pulse Widths.

2.3) Proximity Indicator 6

This is only relevant for Locating Mode

The proximity indicator notifies the user that the target charge range has been reached. This function allows the user to set up an upper and lower limit of charge. When contraction is elicited at the set charge, this indicator should indicate to the user that the needle has reached the desired proximity to the nerve. This proximity is indicated both visually and audibly.

Visual Indication:

- Visually indicated in the diagnostics screen by two arrowheads.
- Arrowhead indicating the lower threshold points upwards.
- Arrowhead indicating the upper threshold points downwards.
- The dotted line representing the selected current will be positioned between the two arrowheads if the target charge range is entered.

Audible Indication:

- A successful stimulus above the proximity range will make a single beep.
- A successful stimulus within the proximity range will make a double beep.
- A successful stimulus below the proximity range will make a triple beep.

2.4) Adjusting the Twitch Frequency 7

Options: 1Hz, 2Hz, 5Hz

Default: 2Hz

Press Enter/Hz button to toggle between different stimulating frequencies.

3

Neuromuscular Transmission Monitoring (NMT) Mode (NMS 450X)

3.1) Introduction to NMT Monitoring

Monitoring Neuromuscular Blocking Agent involves stimulating a neural pathway which facilitates the contraction of an appendage. Based on the relative strength of the contraction which is the result of a stimulus of specific intensity or waveform, it is possible to draw conclusions about the efficacy of an injected Neuromuscular Blocking Agent.

The Stimulation Modes used in NMT are as follows: Train-of-Four, Double Burst, Post Tetanic Count, Supra Maximal Current and Auto modes.

- These modes can be selected when a NMT Monitoring cable is inserted into the Stimpod.

3.2) Cables and Sensors for NMT Monitoring

The Stimpod NMS450X makes provision for two different sensor technologies for NMT Monitoring namely Acceleromyography (AMG) and Electromyography (EMG).

NMT Monitoring Cable (AMG)

In this case the NMT Monitoring Cable is fitted with a tri-axial accelerometer that is attached to the contracting appendage of the patient to measure the strength of the contraction resulting from the applied electrical stimulus.

NMT Monitoring Cable (EMG)

In this case the NMT Monitoring Cable is fitted with an EMG electrode that is attached to the contracting appendage of the patient to measure the action potential of the muscle due to the applied electrical stimulus.

3.3) Stimulation Sites for NMT Monitoring

Electrode placement relies on the cathode (black electrode clip) to be as close to the targeted nerve as possible in order to effectively depolarize the nerve. The anode (red electrode clip) should be away from the targeted nerve.

Anatomical stimulation sites are chosen based on

- Their accessibility during surgery
- The ability to observe the neuromuscular response
- The nerve should be a suitable distance from the responding muscle to prevent direct muscle stimulation

Stimulation Sites Suitable for AMG

AMG: Anatomically Ideal Stimulation Sites		
Targeted Nerve	Affected Muscle	Contracting Appendage
Ulnar nerve	adductor pollicis muscle	Thumb
Posterior tibial nerve	flexor hallucis brevis muscle	Big toe
Facial nerve (Zygomatic Branch)	orbicularis oculi muscle	Eye lid
Facial nerve (Temporal Branch)	corrugator supercili muscle	Eye brow

Stimulation Sites Suitable for EMG

EMG: Anatomically Ideal Stimulation Sites		
Targeted Nerve	Affected Muscle	Contracting Appendage
Ulnar nerve	adductor pollicis muscle	Thumb

3.4) AMG Patient Setup

1 Check Batteries & Switch Device On

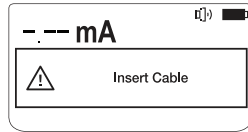
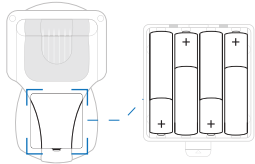

2 Connect NMT Monitoring Cable (AMG)

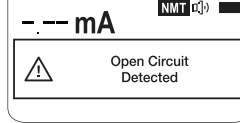
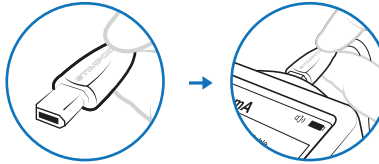

3 Prepare Skin for Monitoring

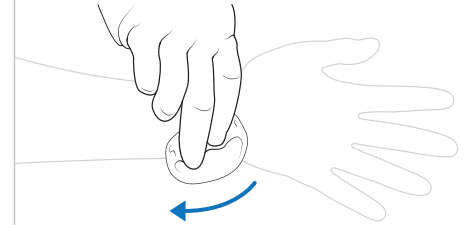

4 Attach Electrodes

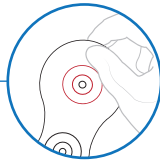

5 Secure Clips to the electrode

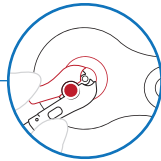

6 Attach Accelerometer to appropriate patient appendage



Patient Setup

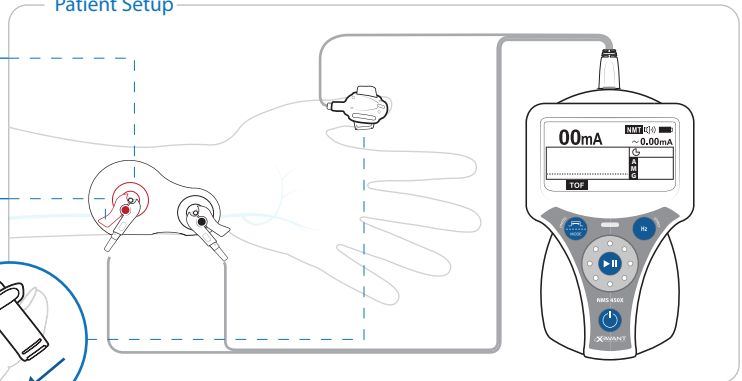

3.5) EMG Patient Setup

1 Check Batteries & Switch Device On

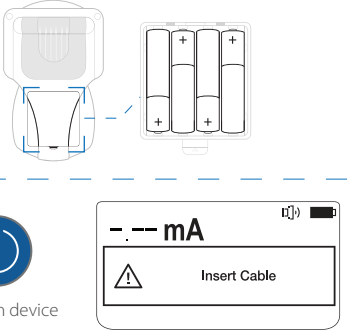

Power on device

--- mA
Insert Cable

2 Connect NMT Monitoring Cable (EMG)

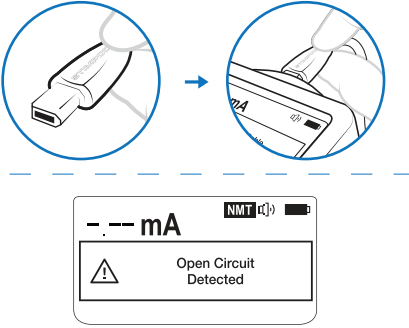

--- mA
Open Circuit Detected

3 Prepare Skin for Monitoring

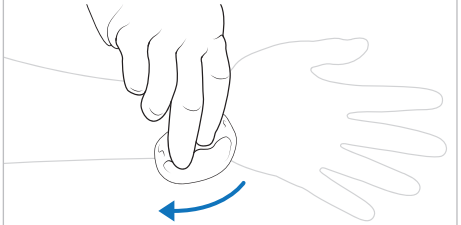

4 Attach EMG Electrode

5 Connect EMG Electrode to NMT Monitoring Cable (EMG)

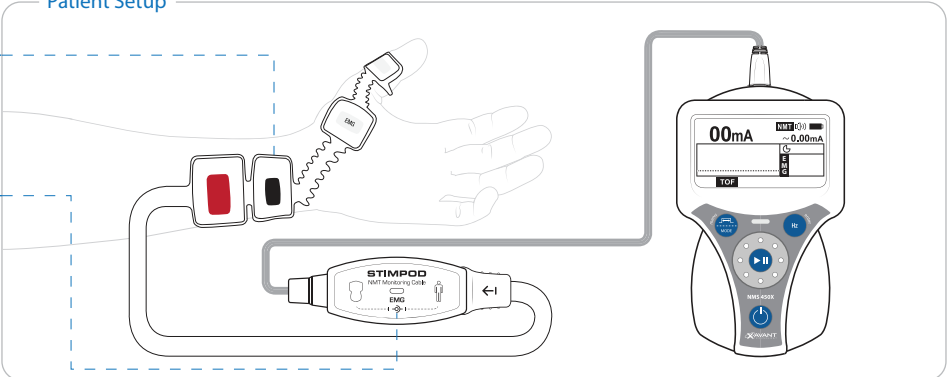

Refractory Period Delay

The three modes: TOF, DB and PTC are subject to refractory period delays, providing a safety period which prevents the user from repeating stimulation while the nerve synapse is recovering from the effects of the previous stimulation.

Immediately after stimulation in one of these modes, the countdown timer is activated and shown on the screen. If repeat mode is activated, only the repeat timer will be displayed on the screen because the repeat period for the repeat timer will always be larger than the refractory period timer. If an attempt is made to stimulate while the refractory timer is active a warning screen will be displayed reminding the user that the refractory period is active.

Default refractory period delays are as follows for the three modes:

TOF: 15 seconds

DB: 1 minute

PTC: 2 minutes



Refractory timer

Only displayed after a single stimulation is completed and is removed after it reaches 00:00.

Single Stimulus vs. Repeated Stimulation

- Start the automatic repeat mode by holding the play/pause button down for longer than 2 seconds.
- The device will automatically start a countdown according to the 'repeat timer' setting as specified in the main menu for each respective mode's timer.
- The countdown will be indicated next to the clock symbol shown in the diagnostic screen.
- Disable the automatic repeat mode by pressing and holding the play/pause button again.
- The Repeat Timer for each mode can be changed in the menu.



Repeat timer notification

This icon (clock) displays when the repeat timer is active.

When using the NMT Mode (NMS 450X)

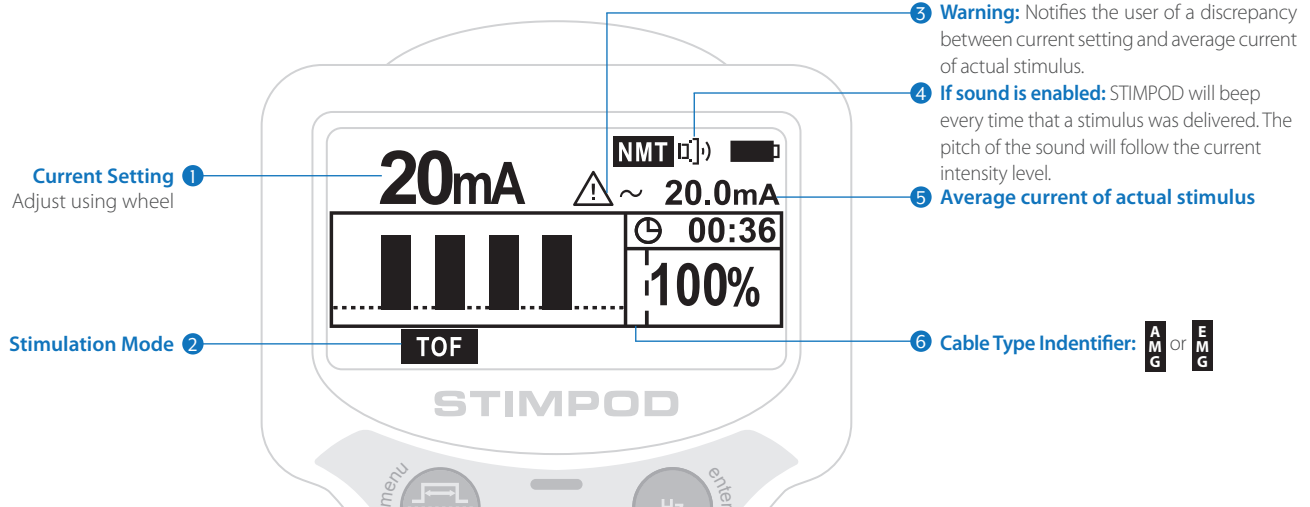

3.6) Adjusting the Current 1

Default Current range: 0 - 80 mA adjustable in 5mA increments.
Circle the Wheel to adjust current.

When the Stimpod starts up in NMT mode, it will revert to the NMT current that was used previously. In order to adjust the current, circle the adjustment wheel, the current setting will flash and start to adjust accordingly. At the same time a warning screen will appear prompting you to press 'enter' to confirm. Press 'enter' to confirm the current change within 2 seconds.

3.7) Adjusting Stimulation Mode 2

Stimulation mode TOF, DB, PTC, TET, TWI, SMC and Auto
Default: TOF

Press Menu/Mode button to toggle between different Stimulation Modes.

3.8) Adjusting Twitch / Tetanus Frequency

N/A	
TWI	2 Hz

Twitch Mode: Options (Stimulating Frequency): 1Hz, 2Hz, 5Hz
Default: 2 Hz

Press Enter/Hz button to toggle between different stimulation frequencies.

Tetanus Mode: Options: 50Hz, 100Hz
Default: 50Hz

Press Enter/Hz button to toggle between different stimulating frequencies.

3.9) Train of Four Mode (TOF)

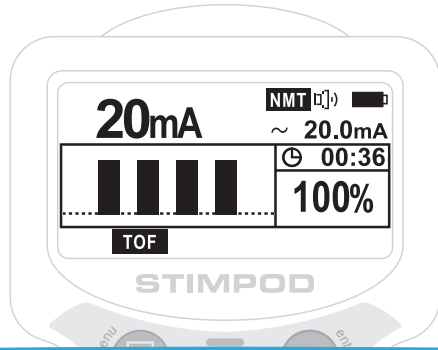

The TOF stimulation comprises four, square waves with a pulse width of 200 microseconds, 500 milliseconds apart.

Selecting TOF Mode:

- Ensure that an NMT Monitoring Cable (AMG/EMG) is inserted in the Stimpod.
- Ensure that TOF is one of the selected Active Modes in the NMT Settings menu (4.3).
- Press the 'Mode' button until 'TOF' is shown on the display.

Real-time Patient Data Displayed:

- The relative contraction strength caused by each stimulus is indicated graphically in the diagnostic screen as shown in the picture.
- In the case that all four contractions could be measured, the percentage of measured contraction strength of the fourth stimulus compared to the first stimulus will be displayed in the diagnostic screen.
- If less than four contractions were measurable, the number of contractions that could be identified will be displayed, i.e. 2/4.

3.10) Double Burst Mode (DB)

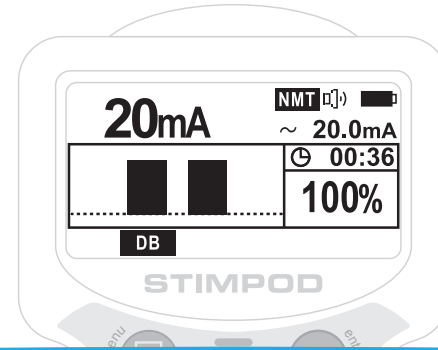

The DB stimulation comprises a burst of three square waves of 200microseconds pulse width, 20 milliseconds apart, followed by another burst of three square waves, 750 milliseconds later.

Selecting DB Mode:

- Ensure that an NMT Monitoring Cable (AMG/EMG) is inserted in the Stimpod.
- Ensure that DB is one of the selected Active Modes in the NMT Settings menu (4.3).
- Press the 'Mode' button until 'DB' is shown on the display.

Real-time Patient Data Displayed:

- The relative contraction strength caused by each stimulus is indicated graphically in the diagnostic screen as shown in the picture.
- The percentage of the measured contraction strength of the second contraction compared to the first contraction will be displayed in the diagnostic screen.

3.11) Post Tetanic Count (PTC)

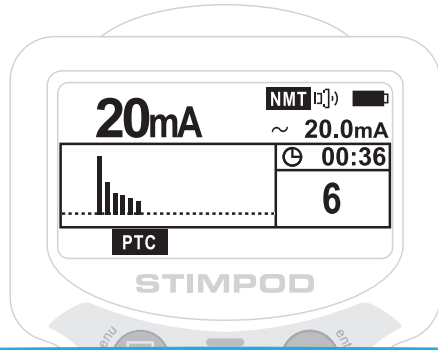

The PTC stimulation comprises a tetanus stimulation followed by a delay and a number of twitches. (Default settings are as shown below)

Defaults:

- Tetanus: 50Hz for 5 seconds
- Delay: 3 seconds
- Twitch: 20 twitches at 1Hz

Selecting PTC Mode:

- Ensure that an NMT Monitoring Cable (AMG/EMG) is inserted in the Stimpod.
- Ensure that PTC is one of the selected Active Modes in the NMT Settings menu (4.3).
- Press the 'Mode' button until 'PTC' is shown on the display.

Real-time Patient Data Displayed:

- Each counted twitch is indicated graphically in the diagnostic screen as shown in the picture. The number of twitches counted are displayed in the diagnostic screen.

3.12) Supra Maximal Current (SMC)

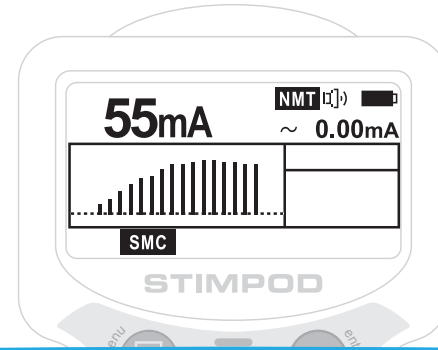

SMC mode is used to find the optimal current for the stimulating electrodes placement. The SMC stimulation comprises of 16 1Hz twitches at increasing current intensities from 5-80mA in 5mA increments. (For Facial mode, this is limited to 8 twitches from 5-40mA). The device will then determine the supra maximal current and change the set current to that value.

Important: SMC mode should only be performed on a non-paralyzed patient.

Selecting SMC Mode:

- Ensure that an NMT Monitoring Cable (AMG/EMG) is inserted in the Stimpod.
- Ensure that SMC is one of the selected Active Modes in the NMT setting menu (4.3).
- Press the 'Mode' button until SMC is shown in the display.

Real-time Patient Data Displayed:

- The relative contraction strength caused by each stimulus is indicated graphically in the diagnostic screen as shown in the picture.

3.13) Auto Mode

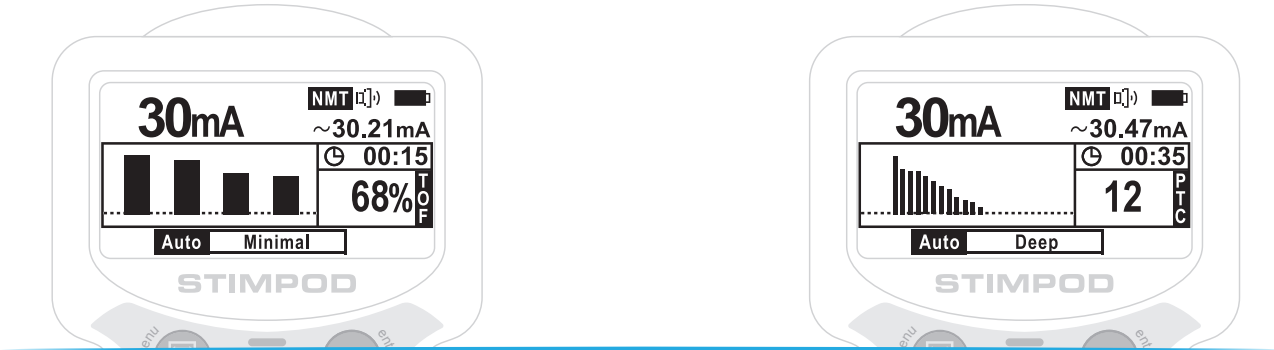

Auto mode is used to conduct Full Case NMT Monitoring. This is achieved through a series of alternating TOF and PTC stimulation sequences to determine the depth-of-block throughout the duration of the procedure.

Selecting Auto Mode

- Ensure that an NMT Monitoring Cable (AMG/EMG) is inserted in the Stimpod.
- Ensure that "Auto" is one of the selected Active modes in the NMT Settings menu (4.3)
- Press the 'Mode' button until 'Auto' is shown on the display.

Real-time Patient Data Displayed

- The relative contraction strengths caused by each stimulation is indicated graphically in the diagnostic screen with the resulting TOF Ratio, TOF Count or PTC Count.
- The Depth of Block is displayed next to the Mode indicator.

Depth-of-Block Zones

The depth-of-block can be classified in terms of six identifiable zones, where each zone indicates the extent of muscle paralysis the patient is experiencing due to the presence of a muscle relaxant.

These zones are:

- Recovered: A TOF ratio of larger than 90%
- Minimal: A TOF ratio of between 40% and 90%.
- Shallow: A TOF ratio less than 40%, but all pulses present.
- Moderate: A TOF count of 1 to 3.
- Deep: A PTC Count of 1 or more.
- Profound: A PTC count of 0.

3.14 Twitch (TWI)

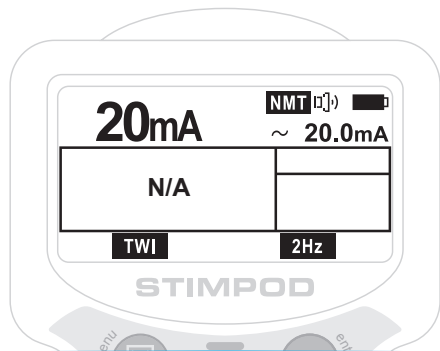

The Twitch stimulation comprises a 200 microseconds square wave pulse. If the 'Play/Pause' button is pressed the twitch will repeat at the selected frequency.

Defaults: Repeat at 2Hz
Adjustable: 1Hz, 2Hz and 5Hz

Selecting TWI Mode:

- Ensure that an NMT Monitoring Cable (AMG/EMG) is inserted in the Stimpod.
- Ensure that 'TWI' is selected in the 'Active Modes' menu option under 'NMT Settings' (4.3)
- Press the 'Mode' button until 'TWI' is shown on the display.
- Press the 'Hz' button to toggle through the frequency options.

Real-time Patient Data Displayed

Stimulation is initiated and stopped by pressing the 'Play/Pause' button. No patient response data is measured in TWI mode.

3.15 Tetanus (TET)

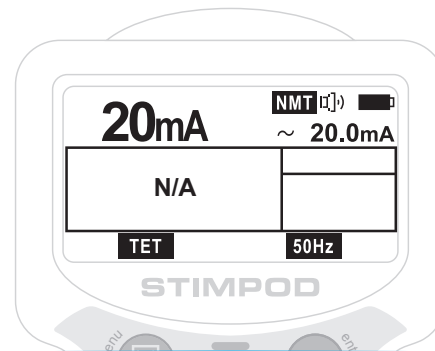

The Tetanus stimulation comprises series of 200 microseconds square wave pulses repeated at a 50Hz or 100Hz repetition rate or frequency.

Defaults: 50Hz (adjustable to 100Hz)

Selecting TET Mode:

- Ensure that an NMT Monitoring Cable (AMG/EMG) is inserted in the Stimpod.
- Ensure that 'TET' is selected in the 'Active Modes' menu option under 'NMT Settings' (4.3)
- Press the 'Mode' button until 'TET' is shown on the display.
- Press the 'Hz' button to toggle through the frequency options.

Real-time Patient Data Displayed:

The stimulation is initiated by pressing and holding the Play/Pause button, and stopped by releasing the Play/Pause button. No patient response data is measured in TET mode.

4

Setting up Device Defaults

The setup menu allows the user to customize device parameters. Access the Setup Menu by pressing and holding the menu button. To exit the menu, the menu button may be pressed again. A block at the top of each menu indicates which menu is currently active.

The menu is controlled using the menu button, the enter button and the wheel. Two blocks at the bottom of the screen indicates what action will occur when a button is pressed, the block bottom left corresponds to the menu button and the block bottom right with the enter button.

In general, the menu button will cause the menu to go back to the previous state or cancel the current action, while the enter button will act on the current menu item (select / accept / toggle). Clockwise rotation on the wheel will generally mean next (menu item / option) or increase (selected value), while counter clockwise will generally mean previous (menu item / option) or decrease (selected value).

4.1) Setup Menu

The setup menu contains 3 sub menus, the contents of each will be covered in detail in the next sections. Use the wheel to select an item and the enter key to enter the corresponding menu. Menu button to exit.

- 1) User Settings – Settings regarding the user's preferences, such as language, buzzer volume, backlight settings and user info.
- 2) NMT Settings – Settings regarding NMT modes such as TOF or PTC. These settings include refractory and repeat timers, active modes and whether the device is currently being used with a facial electrode or not.
- 3) Locate Settings – Settings regarding Locate mode, including proximity indicator levels and current mode settings (linear / non-linear).

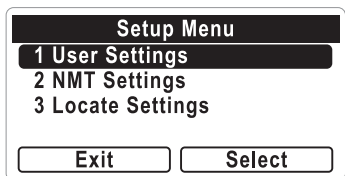

4.2) User Settings

The language, buzzer volume and backlight can be set by scrolling to the appropriate menu item using the wheel, selecting it using the enter button, then changing the selected option using the wheel and accepting the new value using the enter button.

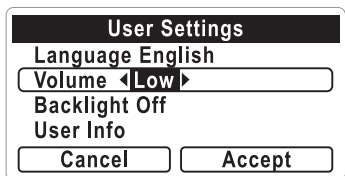

Language options: English (default), French, Italian, Dutch, Spanish, Portuguese, German, Swedish, Danish, Greek, Czech and Polish.



Volume options: Off, Low, Medium (default) and High. During operation, an icon on the main device screen will indicate the currently selected volume.

Backlight options: Off, 5s (on for 5 seconds after last activity), 60s (on for 60 seconds after last activity) and Always On.

Note: The battery life will be drastically shortened if Always On is selected.

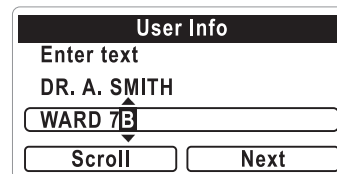
User Info: The User Info menu item will open another menu page which allows the user to enter two lines of personal information of 20 characters each. This menu is controlled using two modes: Edit mode and Scroll mode. To change from Edit mode to Scroll mode, press the menu button and from Scroll mode to Edit mode, press the enter button. In Scroll mode the menu button will close the User Info menu and return to the User Settings menu.



In edit mode the wheel will change the character at the current position. When the desired character is selected, pressing the enter button will move the cursor to the next position. This will happen unless the character is backspace () or enter (). When the current character is the last of the line, the cursor will continue to the line not currently being edited. Backspace will clear the current position and move the cursor to the previous position. The enter character will move the cursor to the start of the line not currently being edited.

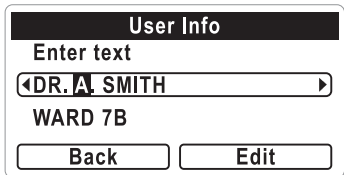

In scroll mode, the wheel can freely change the cursor position. Any character can be selected and then changed in edit mode by pressing the enter button.

4.3) NMT Settings

This menu contains the repeat and refractory timers for TOF, DB and PTC, the AUTO timers for the different levels of block, the active NMT modes and whether facial mode is activated. The active modes and timers are grouped in expandable menu items. To view the contents of an expandable menu item, press the enter button while an expandable item is selected. The contents can then be hidden by pressing the enter button again.

step 1

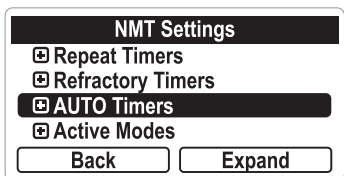

step 2

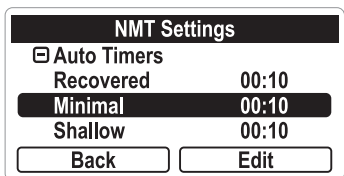

Timers: The timer items are changed in a two-step process, changing the number of minutes first and then the number of seconds. Use the wheel to navigate to the item which should be changed, then press the enter key to start editing.

step 1

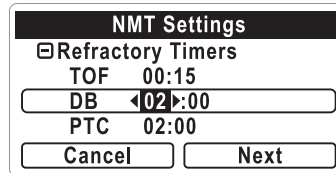

step 2

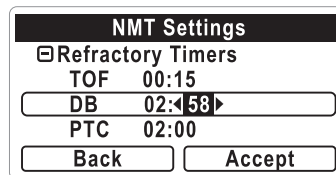

In step 1, the wheel will change the number of minutes. The enter button will accept the value and continue to step 2, while the menu button will revert to the previous timer value and cancel editing. In step 2, the wheel will change the number of seconds. The enter button will accept the timer value and conclude editing. The menu button will return the process to step 1.

Active modes: This can be used to limit the amount of NMT modes which are available during operation to limit the amount of button presses necessary to get to the required mode. Pressing the enter button will toggle the item between active and inactive. The available modes include TOF, DB, PTC, TWI, TET, SMC and Auto.

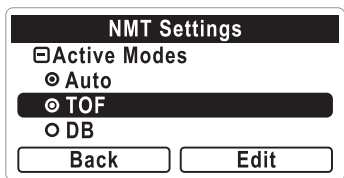

Facial Mode: This item is toggled (On or Off) by pressing the enter key. When on, the resultant current determined by SMC will be limited to a 40mA maximum.

4.4) Locate Settings

Settings which are relevant to the locating mode is managed through this menu. It contains the proximity indicator expandable menu item, current mode item and depending on the selected current mode either linear current mode range settings or an item to navigate to the non-linear settings.

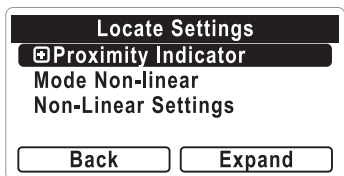

Proximity Indicator: The upper and lower limits of the proximity indicator as described in 2.1 can be set by expanding the proximity indicator menu item, selecting the limit to be changed using the wheel, then pressing enter to start editing and then changing the value using the wheel. When the desired value is reached, the enter button will accept the change. Alternatively, to discard the change press Cancel (menu button).

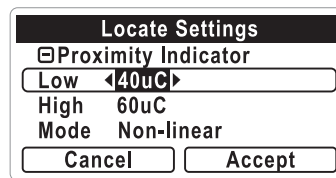

Current mode - Linear: The linear mode is called linear because one 'click' on the wheel will correspond with one increment as set in the specific current range. In the linear mode, Pulse Width is not affected when turning the wheel. Pulse Width is selected when the Menu/Pulse Width button is pressed. The Linear Mode essentially allows the user to select different increment options for each of the three different current ranges.

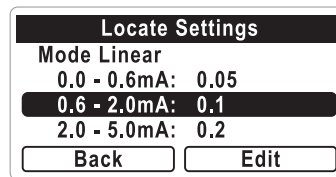

The increment for each range can be set by scrolling to the range to be changed, initiating edit using the enter button and then selecting a different option using the wheel. Each range has preset options which can be selected.

Current Mode – Non-linear: The Non-Linear Mode facilitates the non-linear nature of the current intensity versus the distance from the nerve. The required current intensity is proportional to the square of the distance from the electrode to the nerve fibre.

This mode allows the user to define 20 adjustment positions in terms of current (mA) and pulse width (ms). If correctly implemented each adjustment position should afford the user a relatively linear progression in terms of the distance from needle tip to the nerve.

Position	Current (mA)	Pulse Width (ms)	Charge (μC)
1	0.3	0.1	0.03
2	0.43	0.1	0.043
3	0.58	0.1	0.058
4	0.76	0.1	0.076
5	0.97	0.1	0.097
6	1.2	0.1	0.12
7	1.4	0.1	0.14
8	1.7	0.1	0.17
9	2	0.1	0.2
10	2.3	0.1	0.23
11	2.7	0.1	0.27
12	3	0.1	0.3
13	3.4	0.1	0.34
14	3.8	0.1	0.38
15	4.3	0.1	0.43
16	4.8	0.1	0.48
17	1.8	0.3	0.54
18	2.1	0.3	0.63
19	2.4	0.3	0.72
20	2.7	0.3	0.81

Table 1 Default non-linear settings

These values can be viewed or changed in the Non-linear Settings menu. The charge value for each or the twenty positions are displayed graphically, and the current and pulse width value of each position can be viewed by scrolling to that position using the wheel.

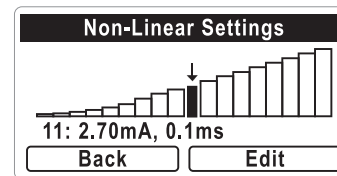

To change the charge at a specific position, a 2 step process can be followed. Select the position which should be changed using the wheel and press the enter button to start step 1. The current is changed using the wheel in this step and the menu button will cancel the change. When satisfied with the current, the enter button can be used to continue to step 2: changing the pulse width. The pulse width for the selected position can be changed using the wheel. The menu button will return to step 1 and the enter button will accept the change and conclude editing.

step 1

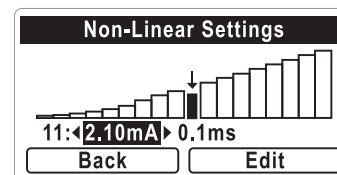

step 2

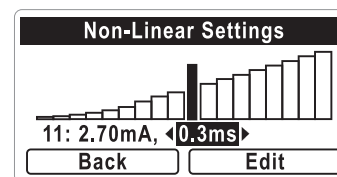

5

Technical Notes

5.1) Performance Test

Before operating and using the device a performance test must be carried out at the site of use. The performance test described below is in compliance with the German § 5 MPBetreibV directive.

- Insert the batteries and switch on the device.
The following screen should appear on the display.



followed by

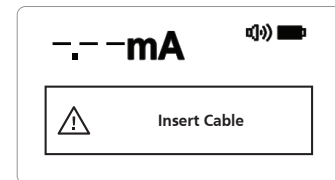

5.1.1) Nerve Locating Mode

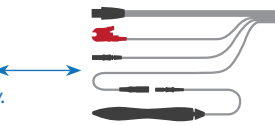
- Insert the Nerve Mapping/Nerve Locating Cable. 
The following screen should appear on the display.

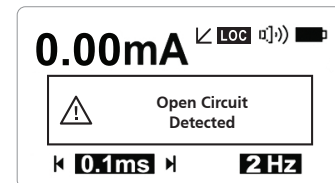

- The LED should flash RED and no audible feedback should be heard.
- Short-circuit the needle connector and the ECG connector.
The following screen should appear on the display.

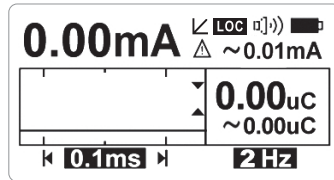

- The LED should flash GREEN and if sound is enabled in the menu a beep should be heard each time a stimulus is delivered.
- Stimulus should occur at the set frequency. (1,2 or 5 Hz).
- Use the adjusting wheel and slowly increase the current to 5.00mA.
- Monitor that the stimulating waveform, measured and displayed in the diagnostic window is square. The top part of the square wave should also touch the dotted line, which represents the current setting as shown below.

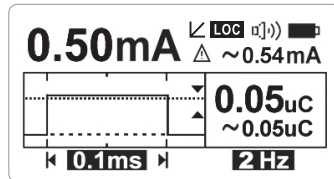

5.1.2) Combined Nerve Mapping/Nerve Locating Mode

- Insert the Nerve Mapping/Nerve Locating Cable. 
The following screen should appear on the display.

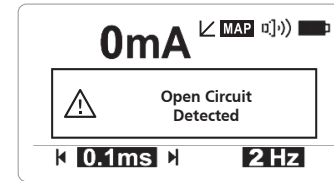
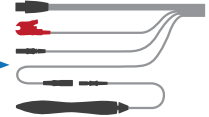

- The LED should flash RED and no audible feedback should be heard.
- Short-circuit the Nerve Mapping probe and the ECG connector.
The following screen should appear on the display.

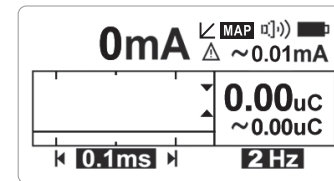

- The LED should flash GREEN and if sound is enabled in the menu a beep should be heard each time a stimulus is delivered.
- Stimulus should occur at the set frequency. (1,2 or 5 Hz).
- Use the adjusting wheel and slowly increase the current to 20mA.
- Monitor that the stimulating waveform, measured and displayed in the diagnostic window is square. The top part of the square wave should also touch the dotted line, which represents the current setting as shown below.

In order to test the Nerve Locating connection and device functionality follow the instructions in 5.1.1.

5.1.3) NMT Monitoring Mode (AMG) (NMS450X only)

- Insert the NMT Monitoring Cable (AMG).  The following screen should appear on the display.

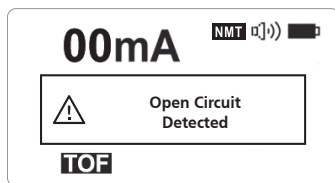

- Ensure that the device is in 'TOF' mode.
- Short-circuit the red and black electrode connectors.

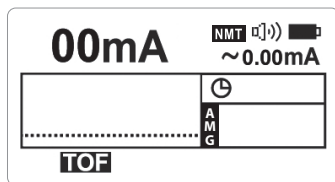

- Use the adjusting wheel and increase the current to 80mA.
- Press the 'play/pause' button while shaking the accelerometer.

The NMS450X should respond as follows:

- The LED should flash GREEN in accordance with the four stimulations.
- Each stimulation should be accompanied by an audible 'beep'.
- In 'Diagnostic window' four bars of different heights should indicate that the accelerometer detected movement.
- Monitor the actual current delivered to ensure that the warning sign does not appear.

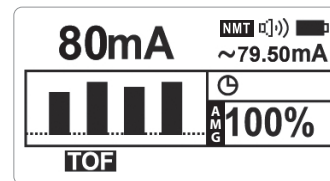

- Separate the red and black electrode connectors to cause an open circuit between them.

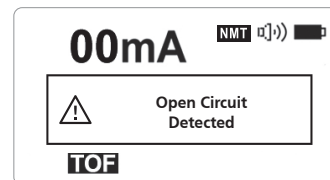

- Press the 'play/pause' button.
- The following screen should appear on the display.
- No audible feedback should be heard.

5.1.4) NMT Monitoring Mode (EMG) (NMS450X only)

- Insert the NMT Monitoring Cable (EMG). 
The following screen should appear on the display.

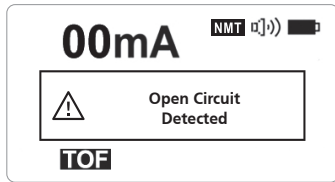

- Ensure that the device is in 'TOF' mode.
- Short-circuit the red and black electrode connectors.

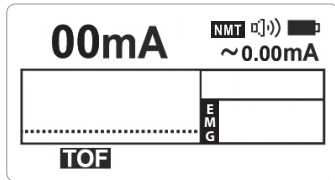

- Use the adjusting wheel and increase the current to 80mA.

The NMS450X should respond as follows:

- The LED should flash green and if sound is enabled in the menu a beep should be heard each time a stimulus is delivered.
- In 'Diagnostic window' no bars should be displayed.
- Monitor the actual current delivered to ensure that the 'Current Warning' sign does not appear.

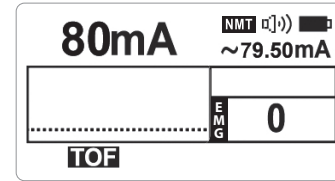

- Separate the red and black electrodes to create an open circuit.

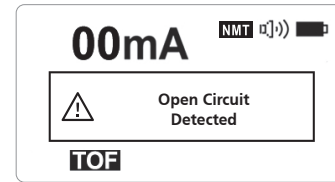

- Press the 'play/pause' button.
- The red LED will flash once.
- No audible feedback should be heard.
- If the STIMPOD malfunctions in any one of these performance tests, it should be checked by the relevant technical department in accordance with the test instructions in the Technical Service Manual.
- Equipment may only be repaired by the manufacturer or by an organisation expressly authorised by the manufacturer.
- Equipment does not require regular calibration.

5.2) Specifications

Operating Modes:	Nerve Locating Mode	Nerve Mapping Mode	NMT Mode
	NMS 410/450X	NMS 410/450X	NMS 450X
Current Range	0.00 - 5.00 mA \pm 5%	0 - 20mA \pm 5%	0 - 80mA \pm 5%
Pulse Width Options	0.05ms, 0.1ms, 0.3ms, 0.5ms, 1ms \pm 5%	0.05ms, 0.1ms, 0.3ms, 0.5ms, 1ms \pm 5%	0.2ms \pm 5%
Maximum Stimulation Voltage	100V	400V	400V
Stimulus	Monophasic square wave	Monophasic square wave	Monophasic square wave
Stimulating Frequency	1Hz, 2Hz, 5Hz \pm 5%	1Hz, 2Hz, 5Hz \pm 5%	1Hz, 2Hz, 5Hz, 50Hz, 100Hz \pm 5%
Load Impedance	0 kOhm - 20 kOhm	0 kOhm - 20 kOhm	0 kOhm - 5 kOhm

Technical Specifications	NMS 410/450X
Device Classification	Class IIa, Type BF
Power Supply	4 x AAA alkaline batteries
Power Consumption	17mA
Waveform	Constant Current, Monophasic Square Wave
Weight	130g
Dimensions	145mm x 90mm x 30mm
Operating Temperature	10 - 40 ° Celsius
Storage and Transport Temperature	0 - 50 ° Celsius
Operating Humidity	90% Relative Humidity
Transport and Storage Humidity	90% Relative Humidity
Operating Atmospheric Pressure	50 - 106kPa
Transport and Storage Atmospheric Pressure	50 - 106kPa

5.3) Cleaning and Disinfecting STIMPOD NMS 410/450

Cleaning: Soap and water, applied with a damp cloth is suitable to clean and disinfect the STIMPOD. It is imperative that no moisture penetrates the STIMPOD.

Disinfecting: Any commercially available methanol - free disinfectant in an ethyl alcohol base can be used for disinfection.

5.2) Guidance and Manufacturers Declaration

Guidance and manufacturers declaration – electromagnetic emissions– for all equipment and systems

The STIMPOD NMS 410/450X is intended for use in electromagnetic environment specified below. The customer or user of the STIMPOD NMS 410/450X should assure that it is used in such an environment

Emission Test	Compliance	Electromagnetic Environment – Guidance
RF Emissions CISPR 11	Group 2 – Class A	The STIMPOD NMS 410/450X must emit electromagnetic energy in order to perform its intended function. Nearby electronic equipment may be affected.
		<p>The STIMPOD NMS 410/450X is suitable for use in all establishments, other than domestic establishments and may be used in domestic establishments and those directly connected to the public low voltage power supply network that supplies buildings used for domestic purposes, provided the following warning is heeded:</p> <p>WARNING: This equipment/system is intended to be used by healthcare professional only. This equipment/system may cause radio interference or disrupt the operation of nearby equipment. It may be necessary to take mitigation measures, such as re-orienting or re-locating the STIMPOD NMS 410/450X or shielding the location</p>

Guidance and manufacturers declaration – electromagnetic immunity- for all equipment and systems

The STIMPOD NMS 410/450X is intended for use in the electromagnetic environment specified below. The customer or the user of the STIMPOD NMS 410/450X should assure that it is used in such an environment

Immunity Test	IEC 60601 test level	Compliance level	Electromagnetic environment - guidance
Electrostatic discharge (ESD) IEC 61000-4-2	± 6 kV contact ± 15 kV air	± 6 kV contact ± 15 kV Air	Floors should be wood, concrete or ceramic tile. If the floors are covered with synthetic material, the relative humidity should be at least 30%
Power frequency (50/60 Hz) magnetic field IEC 61000-4-8	30 A/m	50 Hz 30 A/m (Effective)	Power frequency magnetic fields should be at levels characteristic of a typical location in a typical commercial or hospital environment.

Guidance and manufacturer's declaration – electromagnetic immunity

The STIMPOD NMS410/NMS450X is intended for use in the electromagnetic environment specified below. The customer or the user of the STIMPOD NMS 410/450X should assure that it is used in such an environment.

Immunity test	IEC 60601 test level	Compliance level	Electromagnetic environment – guidance
Conducted RF IEC 61000-4-6	3V at 0.15 - 80MHz and 6V at ISM Frequency. Home Healthcare: 3V at 0.15-80MHz, and 6V at ISM and Radio Amateur Frequency.	3V at 0.15 - 80MHz and 6V at ISM Frequency. Home Healthcare: 3V at 0.15-80MHz, and 6V at ISM and Radio Amateur Frequency.	<p>Portable and mobile RF communications equipment should be used no closer to any part of the STIMPOD NMS 410/450X, including cables, than the recommended separation distance calculated from the equation applicable to the frequency of the transmitter.</p> <p>Recommended separation distance</p> <p>$d = 1,2 \sqrt{P}$ 80 MHz to 800 MHz</p> <p>$d = 2,3 \sqrt{P}$ 800 MHz to 2,5 GHz</p> <p>where P is the maximum output power rating of the transmitter in watts (W) according to the transmitter manufacturer and d is the recommended separation distance in metres (m).</p> <p>Field strengths from fixed RF transmitters, as determined by an electromagnetic site survey,^a should be less than the compliance level in each frequency range.</p> <p> Interference may occur in the vicinity of equipment marked with the following symbol:</p>
Radiated RF IEC 61000-4-3	3 V/m (10V/m Home Healthcare) at 80-2,700MHz, AM Modulation. And 9-28V/m at 385-6000MHz, Pulse Mode and other Modulation (upon Risk Analysis).	3 V/m (10V/m Home Healthcare) at 80-2,700MHz, AM Modulation. And 9-28V/m at 385-6000MHz, Pulse Mode and other Modulation (upon Risk Analysis).	

NOTE 1 At 80 MHz and 800 MHz, the higher frequency range applies.

NOTE 2 These guidelines may not apply in all situations. Electromagnetic propagation is affected by absorption and reflection from structures, objects and people.

^a Field strengths from fixed transmitters, such as base stations for radio (cellular/cordless) telephones and land mobile radios, amateur radio, AM and FM radio broadcast and TV broadcast cannot be predicted theoretically with accuracy. To assess the electromagnetic environment due to fixed RF transmitters, an electromagnetic site survey should be considered. If the measured field strength in the location in which the STIMPOD NMS 410/450X is used exceeds the applicable RF compliance level above, the STIMPOD NMS 410/450X should be observed to verify normal operation. If abnormal performance is observed, additional measures may be necessary, such as re-orienting or relocating the STIMPOD NMS 410/450X.

Recommended separation distances between portable and mobile RF communications equipment and the STIMPOD NMS410/450X

The STIMPOD NMS 410/450X is intended for use in an electromagnetic environment in which radiated RF disturbances are controlled. The customer or the user of the STIMPOD NMS 410/450X can help prevent electromagnetic interference by maintaining a minimum distance between portable and mobile RF communications equipment (transmitters) and the STIMPOD NMS 410/450X as recommended below, according to the maximum output power of the communications equipment.

Rated maximum output power W	Separation distance according to frequency of transmitter m		
	150 kHz to 80 MHz Not applicable	80 MHz to 800 MHz $d = 1,2 \sqrt{P}$	800 MHz to 2,5 GHz $d = 2,3 \sqrt{P}$
0,01	-	0,12	0,23
0,1	-	0,38	0,73
1	-	1,2	2,3
10	-	3,8	7,3
100	-	12	23

For transmitters rated at a maximum output power not listed above, the recommended separation distance d in metres (m) can be estimated using the equation applicable to the frequency of the transmitter, where P is the maximum output power rating of the transmitter in watts (W) according to the transmitter manufacturer.

NOTE 1 At 80 MHz and 800 MHz, the separation distance for the higher frequency range applies.

NOTE 2 These guidelines may not apply in all situations. Electromagnetic propagation is affected by absorption and reflection from structures, objects and people.

Guidance and manufacturers declaration – electromagnetic immunity – for equipment and systems that are non- life supporting

The STIMPOD NMS 410/450X is intended for use in the electromagnetic environment specified below. The customer or the user of the STIMPOD NMS 410/450X should assure that it is used in such an environment

Immunity Test	IEC 60601 test level	Compliance level	Electromagnetic environment - guidance
Radiated immunity 80MHz - 2.5GHz	80MHz – 1GHz @ 3V/m & 10V/m 1GHz – 2.5GHz @ 10V/m	80MHz – 1GHz @ 3V/m & 10V/m 1GHz – 2.5GHz @ 10V/m	Portable and mobile RF communications equipment can affect MEDICAL ELECTRICAL EQUIPMENT and should be used no closer to any part of the equipment, including cables, than the recommended separation distance.

Products & Accessories

STIMPOD NMS410 KIT: PRECISION NERVE LOCATOR

(Including Nerve Locating/Mapping Cable, Carry Case, IFU)

Product Code XT-41011

STIMPOD NMS450 KIT: QUANTITATIVE NMT MONITOR AMG (1.8M)

(Including Nerve Locating/Mapping cable, NMT Monitoring Cable AMG (1.8m), Carry Case, IFU)

Product Code XT-45021

STIMPOD NMS450 NMT MONITOR KIT AMG (1.8M)

(Including NMT Monitoring Cable AMG (1.8M), Carry Case, IFU)

Product Code XT-45021D

STIMPOD NMS450 KIT: QUANTITATIVE NMT MONITOR EMG (1.8M)

(Including NMT Monitoring Cable EMG (1.8m), Carry Case, IFU)

Product Code XT-45021B

NERVE LOCATING/MAPPING CABLE

Product Code: XT-41014

NMT MONITORING CABLE AMG (1.8m)

Product Code: XT-45025

NMT MONITORING CABLE AMG (3.5m)

Product Code: XT-45025A

NMT MONITORING CABLE EMG (1.8m)

Product Code: XT-45003

NMT MONITORING CABLE EMG (3.5m)

Product Code: XT-45003A

NMT ELECTRODE (Pack of 10)

Product Code: XT-45008

EMG ELECTRODE LARGE (Pack of 1)

Product Code: XT-45009L

EMG ELECTRODE SMALL (Pack of 1)

Product Code: XT-45009S

ACCELEROMETER STRAP (Pack of 5)

Product Code: XT-45007

POLYPROPYLENE CARRY CASE

Product Code: XT-41002

INSTRUCTIONS FOR USE

Product Code: XT-45006-EN

(Refer to www.xavant.com for additional languages)





(01)6009880396221(10)xxxxxxxx

XAVANT
TECHNOLOGY

Unit 102, The Tannery Industrial Park, 309 Derdepoort Rd
Silverton, Pretoria, South Africa, 0184
Tel: +27 (0) 12 743 5959, E-mail: support@xavant.com
Web: www.xavant.com

XAVANT
TECHNOLOGY