

Laboratory Centrifuge EICKEMEYER®

USER'S MANUAL OPERATION / MAINTENANCE AND PARTS LIST

Content

Safety information, product information	1
Intended use, installation, definition	2
Tubes information	3
Grounding	4
How to install testing tubes	5
Operation	6
Recalibration procedure for speed	7
Speed and RCF indication	8
Disassembly	9
Maintenance & Servicing	10
Troubleshooting	11
Direction and environmental condition for clean, operation.....	12
Diagram of components	13
Parts list	14
Wiring diagram	15

Safety information

Your **EICKEMEYER®** Table Top Centrifuge has been designed with functions, reliability, and safety in mind. This manual contains important operation and safety information. The users must carefully read and understand the contents of this manual prior to installing your centrifuge in conformance with your local electrical codes.

Classification: This Centrifuge is classified as "Class I" equipment.

Thermal cutout operation temperature.. 105°C

CE marking.. The manufacturer also declares the conformity with the actual required safety standards in accordance with LVD 73/23 EEC.

Standard:

- This equipment complies with EC Electromagnetic Compatibility requirement of EN60601-1-2. EMI filter is designed in conformity with 89/336 EEC-EMC Directive.
- ISO9001+13485,
- GMP (Good Manufacturing Practice)
- FDA registered (USA)

Product's briefing..

This equipment is a Class 1 tabletop centrifuge with timers of 60 minutes maximum and a speed control knob. The motor has a max speed of 4000 – 4500 rpm and fitted with a thermal cut-off to cut the power in abnormal temperature condition. There is no heating element. The power cord is non-detachable. Two PC boards are installed, one is for power filtering, one is for the speed control. There is no applied part for patients and not suitable for the use in special environment.

Motor.. AC, carbon brush, your choice of 67W or 90W

power.. 110V/60HZ or 220V/50HZ

rotor.. 45° fixed angle rotor

Suggested Tubes:

5ml: 12 x 75mm

10ml: 16 x 100mm Length

15ml: 17 x 117mm (or120mm)

Intended use:

This equipment is to provide a laboratory test within the range of 1000 – 4500 rpm for test tubes containing in ***vitro diagnostic*** specimens for qualitative or quantitative test procedures. Refer to the clinic laboratory method specified by the reagent manufacturer or established by medical technology for products applications.

Installation:

- 1 / Strip the packing materials
- 2 / Open the cover of the carton box and remove the artificial form
- 3 / Carry the centrifuge carefully from the carton box;
- 4 / Remove the plastic bag from the centrifuge;
- 5 / Place centrifuge onto a sturdy and flat table.
- 6 / Don't drop the equipment and don't place the equipment upside down.

Content..

- Rotor : 1
- Carbon brush : 1 pair spare carbon brush
- Fuse : 1
- Adaptor : Corresponding to the rotor.
- Power Cord .. 3-wire (CSA type, SVT 105°C, 18AWG x 2 C)

Definition..

- **g Force**
The measurement for samples undergoing the stress of acceleration in a centrifuge.
- **RCF (Relative Centrifugal Force)**
RCF is the centrifugal force that the samples undergoes which relies on the speed of rotation (**N**) in rpm and the rotating radius (cm) (**R**). The rotating radius is measured from the center axis of rotor to the extreme end of the centrifuge tubes.

Formula: $RCF = 11.18 \times R \times (N / 1000)^2$

A-0815: Ø 21.1cm;

A-1215: Ø 22.7cm

TUBES

- **Round bottom**

Have a uniform wall thickness and provides a better fit in a rotor than conical bottom tubes. Round tubes withstand higher g-forces.

- **Conical bottom**

Ideal for cell culturing and ammonium sulfate precipitations.

1. All centrifuges have come with the tube holders, in which a rubber cushion is installed inside the tubes.
2. The tube adaptor is applied to the volume either 10ml or 15ml.
3. Do not place the cushion upside down or in a slant position.
4. Replace the cushion once the glass tube is broken.
5. Be sure the tube adaptors are placed into the rotor completely.

Grounding

This centrifuge is installed with a 3-pin electric cable. Be sure to well connect the grounding wire to the terminal.

WARNING:

Do not connect the grounding pin to the following areas:

1. Gas piping or faucet
Explosion or fire may occur
2. Other wires or lighting
Electric shock or fire may occur
3. Other electrical applicants.

HOW TO INSTALL TESTING TUBES

The balance of rotor has been well calibrated in house thoroughly before delivery, the user is again requested to install the testing tubes in the correct way carefully prior to spinning this centrifuge as depicted below:

1. Place the testing tubes into the tube adaptors diagonally and symmetrically to balance the rotor. Please refer to the figure.
2. Place the testing tubes gathering on one single side will create imbalance of rotor, which will possibly cause vibration of rotor.
3. If odd number of testing tube is used, supplement another dummy tube to remedy the problem.

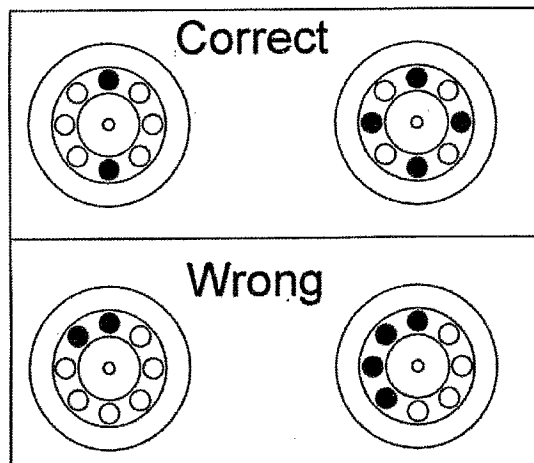

OPERATION:

- Check the specification label located on back of this equipment.
- Plug cord in a properly grounded outlet.
- Place the test tubes into the tube adaptors. Be sure to place the tubes diagonally and symmetrically to keep the rotor balanced.
- Close the cover completely. NOTE, Locking latch is optional.
- Dial preset your desired time by turning the control knob for any spin interval from 0 – 60 minutes. This equipment is working by timer-activated operation.
- When turn clockwise the timer, the pilot lamp will light up at the same time, which indicates the power up.
- Adjust the control knob of speed regulator to bring speed to your desired operation speed and centrifugal force.
- This centrifuge does not include the speed indicator, the reference of speed and RCF is depicted below. Nevertheless, the user is recommended to measure the speed by a hand held LCD tachometer in order to achieve a correct speed and RCF.
- Speed and RCF varies slightly centrifuge to centrifuge.
- The bell rings and power will shut out automatically when the set time has elapsed and the pilot lamp will distinguish simultaneously.

WARNING..

- Do not open the lid only until the rotor has stopped completely.
- Do not stop the rotor by hand. There is possibility of personal injury.
- **EICKEMEYER®** will not ensure the responsibility if user violate the above regulation.

Recalibration Procedure for Speed:

This centrifuge was initially set by its speed from 1000 – 4500 rpm (or 4000 rpm for PLC-05) in house. Supposed that the min/max speed is varied, the control can be recalibrated as depicted below:

- 1 · Remove the bottom plate, switch power on by turning control knob of timer. **CAUTION: Electrical Shock**
- 2 · Turn knob of speed regulator to the extreme **LOW** position. Adjust part of SVR P2/204 (for the low 1000 rpm control) right/left to get the desired speed of 1000rpm.
- 3 · To recalibrate the speed for 4000 or 4500rpm, turn speed regulator to the extreme **HIGH** position, then adjust SVR (P1/104) right/left slightly until it reaches 4000 or 4500 rpm.
- 4 · The calibration of LOW or HIGH speed can influence each other; thus the user is recommended to use the digital speed indicator and measure the result of the recalibration. Repeat the above procedure until the final speed indication meets your requirement.
- 5 · Switch off the power and assemble the bottom plate.
- 6 · Glue the parts of SVR (P1/104 and P2/204) after the speed recalibration is finished. The transportation and vibration may probably loosen the electronic parts and fasteners.

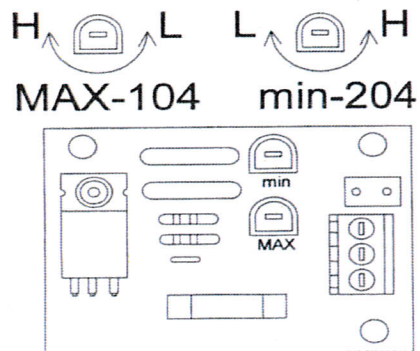

WARNING:

Electric shock and Personal injury. Always proceed with caution.

Speed and RCF Indication

The speed and RCF may be varied centrifuge to centrifuge caused by its surrounding power consumption, which will result in a fluctuation of speed. To assure an accurate rpm and its corresponding RCF, do not place this equipment in the draft, sunlight or near a piece of equipment that emits heat as well as Electromagnetic conduction emission.

1. Motor 67W (Average values from 5 random samplings)

TIMER	PLC-01 ~ PLC-03		PLC-04~PLC05	
	Speed	RCF	Speed	RCF
LOW	1026	124 x g	1018	132 x g
1	1130	150	1123	160
2	1242	182	1262	202
3	1355	216	1603	326
4	1553	285	1810	416
5	1855	406	2055	536
6	2350	651	2280	660
7	3024	1079	2760	967
8	3447	1401	3100	1220
9	4030	1916	3585	1631
HIGH	4460	2346	3960	1990

2. Motor 90 W (Average values from 5 random samplings)

TIMER	PLC-01 ~ PLC-03		PLC-04 ~ PLC-05	
	Speed	RCF	Speed	RCF
LOW	1000	118 x g	1000	127 x g
1	1056	132	1080	148
2	1165	160	1170	174
3	1305	201	1270	205
4	1485	260	1390	245
5	1672	330	1543	302
6	1940	445	1770	398
7	2405	682	2016	516
8	2863	967	2628	876
9	3815	1717	3550	1600
HIGH	4500	2390	4003	2033

- Confidence interval: $\pm 95\%$
- User is recommended to measure speed and RCF by digital speed indicator to achieve the practical values.

DISASSEMBLY:

WARNING..

For sake of safety, the disassembly must be done the qualified personnel or licensed engineers only. **EICKEMEYER®** will not ensure the responsibility if user violates this regulation.

- Remove the bottom plate by loosening the set-screw.
- Loosen the nuts from rubber supports attached to the base to remove the rack of motor
- Unscrew the motor from the rack
- Disconnect wires from assembly prior to disassemble the electronic parts.
- Loosen the bolt to remove the rotor.
- Remove the control knobs of timer and speed regulator by loosening the screws on it.
- The front control panel is glued.
- Unscrew the set bolts to remove timer and speed regulator.
- Loosen screws for chamber removal.
- Always disconnect from power supply prior to disassembly.

WARNING..

- Disconnect from power supply prior to disassembly of this equipment.
- People other than the qualified personnel or licensed engineers are strictly prohibited for disassembly.

MAINTENANCE & SERVICING

- To avoid electrical shock, always disconnect from power supply prior to maintenance & Servicing.
- People other than the qualified personnel or licensed engineers are strictly prohibited from maintenance and servicing.
- Always use a properly grounded electrical outlet of correct voltage and current handling capacity.
- Always inspect the rubber supports, replace the new one when required in order to keep the balanced rotor.
- Clean the chamber and rotor after use of this equipment.
- ~~Do not drop this equipment. Do not place this equipment upside down.~~
- The drive motor and linkage assembly do not require lubrication.
- Always inspect the balance and speed at least once a month.
- Inspect and replace the carbon brushes yearly or according to the operation frequency or whenever it needs.
- Use compressor to clean the dust inside the chamber that is generated by the carbon brushes. Wearing the mask while cleaning the dust to protect your respiratory system.
- Carbon brushes are required from the origin of supplier. The nature of carbon brushes, such as hardness and dimension, is connection with the motor design. The carbon brushes out of the origin of supplier will damage the motor.
- The life of carbon brushes depends on the using frequency. Always inspect the carbon brushes status and replace new ones when required.
- Inspect micro-switch and see if the function of automatic shutout safety device is working.
- A 5A.-fuse is equipped inside the circuit board to encounter the abuse of voltage, so as to protect the electronic parts and motor from burnout.
- Inspect the speed indicator and see if its variable is accurate or not. Calibrate the speed indicator if it can't match the practical value. (see Page 7: Recalibration Procedure for Speed)

Troubleshooting:

Problem	Possible cause	Corrective action
Vibration	- Rotor imbalance - Defective rubber support	- Place tubes symmetrically - Replace new one
Erratic speed	- Worn out carbon brushes - Defective triac or VR	- Replace new ones - Replace parts
Failure of operation	- Worn out brushes - Defective motor or PCB - Blowout fuse - Disengaged linkage	- Replace carbon brushes - Replace parts - Replace fuse - Connect linkage
Burnout motor & PCB	- Wrong power supply - Overload current	Use the right power source
Change of MAX and MIN rpm	- Loose SVR of PCB	- Calibrate speed. See Page 7 for correction
Timer can't work	- Counting failure	- Turn timer to 60min, then turn to 0 before set time.
Tilted rotor	- Loose fastener attached to motor - Broken rubber support	- Fix and glue the fastener - Replace new one
Failure of motor spinning	- Worn out carbon brushes - Malfunction of PCB - Burnout motor - Disengaged wiring	- Replace carbon brushes - Replace PCB - Replace motor - Connect wirings

NOTE..

- Troubleshooting must be done by the qualified personnel only.
- The drive motor and linkage assembly do not require lubrication
- Immerse the centrifuge in water is strictly prohibited
- Disassembly must be performed under the supervision of licensed engineers
- Tip the equipment up or place upside down or vibrate the equipment may damage the equipment
- Take care of the electrical shock for troubleshooting.
- Always refer troubleshooting to your local distributors.
- Unstable voltage and current can shorten the lifespan of this centrifuge. We recommend you use the voltage stabilizer.

Direction to Clean:

- Disconnect from power supply prior to clean.
- Clean the equipment after every use.
- Use a moist cleaning cloth to clean the case, rotor and tube holders
- Dry the equipment thoroughly before operation.
- Do not immerse this equipment in water.
- Never use benzine or paint thinner for cleaning.

Transportation

- Fragile, Handle with Care
- Use no hook
- Do not drop this equipment
- Do not place this equipment upside down.
- Pack this equipment in carton box for transportation.
- Prevent this equipment from vibrating.

Storage:

- Do not place this equipment in the draft, sunlight or near a piece of equipment that emits heat and electromagnetic conduction emission.
- Disconnect power supply while store this equipment.
- This equipment shall be stored under the condition of room temperature
- Do not place any heavy load on this equipment.

Environmental Conditions for Operation & Storage:

- Temperature 10° C – 40°C
- Humidity 40 % – 90 %
- Sea level altitude ≤ 4000 meters
- Atmospheric pressure range of 700hPa to 1060hPa

NOTE:

- This equipment complies with EC Electromagnetic Compatibility requirement of EN60601-1-2
- EMI filter is designed in conformity with 89/336 EEC-EMC Directive
- This equipment complies with IEC801 series regulations.

Diagram of Components

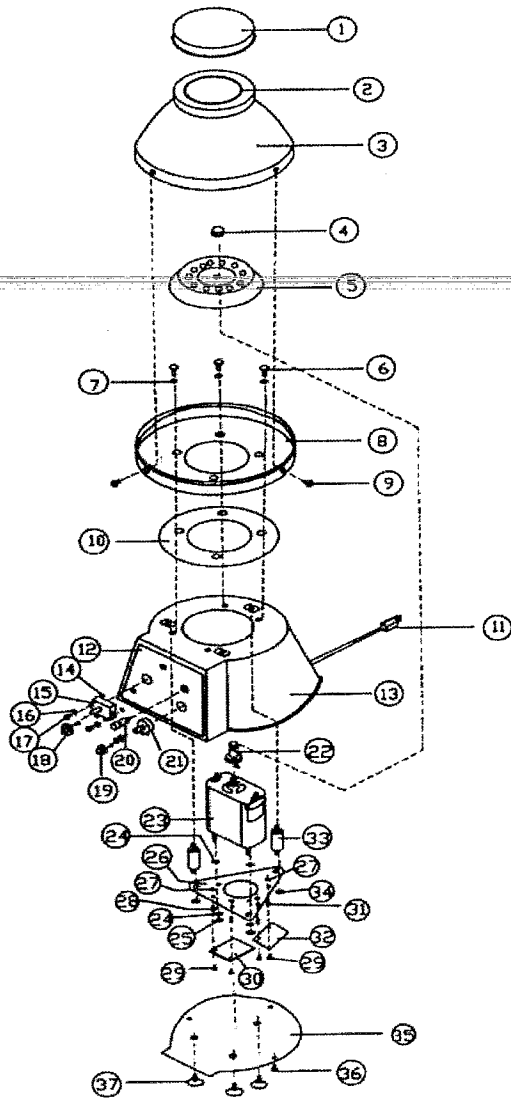

Part List

No.	Description	No.	Description
1	Lid	19	Control knob, speed
2	Plastic gasket	20	Pilot lamp
3	Chamber, upper	21	Speed regulator, VR
4	Fastener, rotor	22	Brass connector, rotor+motor
5	Rotor, alloyed aluminum	23	Motor, AC (67W or 90W)
6	Bolt, 3 required	24	Washer
7	Bolt, 3 required	25	Nut
8	Chamber, lower	26	Rack, motor
9	Screw, 3 required	27	Fastener
10	Rubber gasket	28	Fastener
11	Power cord	29	Fastener
12	Control panel	30	Circuit board
13	Base	31	Fastener
14	Fastener	32	EMI
15	Timer, 60 minutes	33	Rubber support, 3 required
16	Washer	34	Fastener
17	Fastener, timer	35	Bottom plate
18	Control knob, timer	36	Fastener
		37	Suction feet, 3 required

NOTE..

When ordering for replacement, be sure to order by its part number and description.

Wiring diagram

A: With Safety Shutout Locking Lid

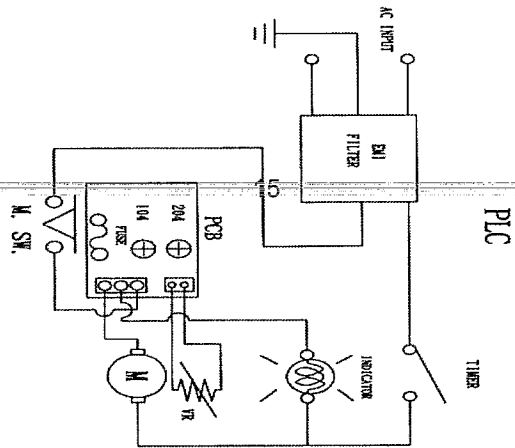

B: Natural Braking Device

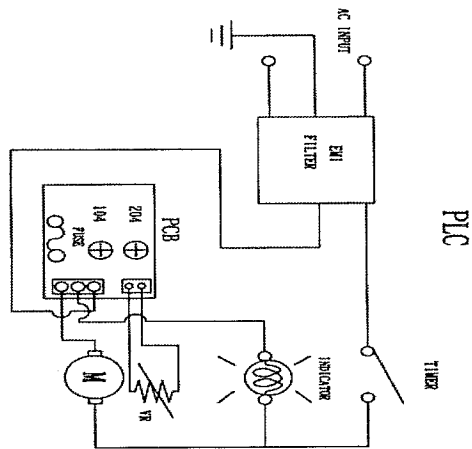

One Year Limited Warranty

Your **EICKEMEYER®** product is guaranteed to be free from defects in materials and workmanship for one (1) year under normal use from the date of purchase.

This **WARRANTY** does not apply to any product damaged by accident, misuse, abuse, neglect, improper line voltage, drop, fire, flood or if the products were altered or repaired by anyone other than the qualified service personnel.

The liability of EICKEMEYER® Industrial Corp. is limited to repair or replacement and under no circumstances shall EICKEMEYER® be liable for any collateral consequential damages or losses. This guarantee specifically excludes the expendables and consumables.

All warranty claims must be directed to the distributors or agents authorized by EICKEMEYER® Industrial Corp. responsible for the sale of this equipment. The users are responsible for shipping expenses.

Purchase Record

Company name: _____

Address : _____

Phone No. : _____

Fax No. : _____

Email address : _____

Date of purchase: _____

Product Model : _____

Serial No. : _____

Distributor : _____
